

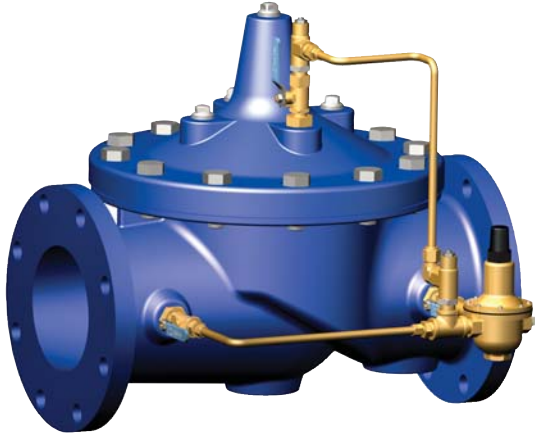

90-01
(Full Internal Port)
MODEL
690-01
(Reduced Internal Port)

Pressure Reducing Valve



- Sensitive and Accurate Pressure Control
- Easy Adjustment and Maintenance
- Tamper Resistant
- Optional Check Feature
- Fully Supported Frictionless Diaphragm

The Cla-Val Model 90-01/690-01 Pressure Reducing Valve automatically reduces a higher inlet pressure to a steady lower downstream pressure, regardless of changing flow rate and/or varying inlet pressure. This valve is an accurate, pilot-operated regulator capable of holding downstream pressure to a pre-determined limit. When downstream pressure exceeds the pressure setting of the control pilot, the main valve and pilot valve close drip-tight.

If a check feature is added, and a pressure reversal occurs, the downstream pressure is admitted in the main valve cover chamber, closing the valve to prevent return flow.

Schematic Diagram

Item	Description
1	Hytrol (Main Valve)
2	X58 Restriction Fitting
3	CRD Pressure Reducing Control

Optional Features

Item	Description
A	X46A Flow Clean Strainer
B	CK2 (Isolation Valve)
C	CV Flow Control (Closing)*
D	Check Valves with Isolation Valve
S	CV Flow Control (Opening)
Y	X43 "Y" Strainer

*The closing speed control (optional) on this valve should always be open at least three (3) turns off its seat.

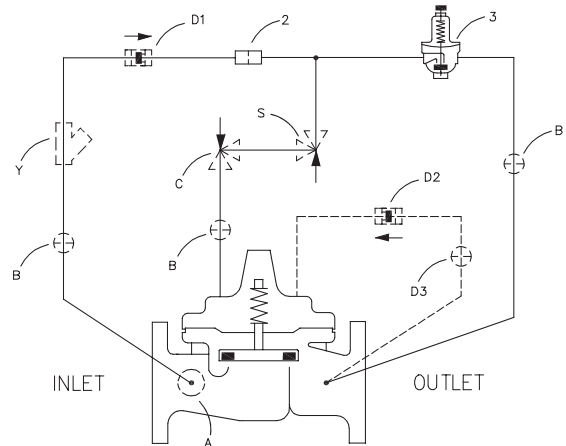

Typical Applications

Typical applications include pressure reducing valve station using Model 90-01BY/690-01BY and Model 90-01AS/690-01AS in parallel to handle wide range of flow rates. Larger Model 90-01BY/690-01BY valve meets requirements of peak loads and smaller Model 90-01AS/690-01AS handles low flows.

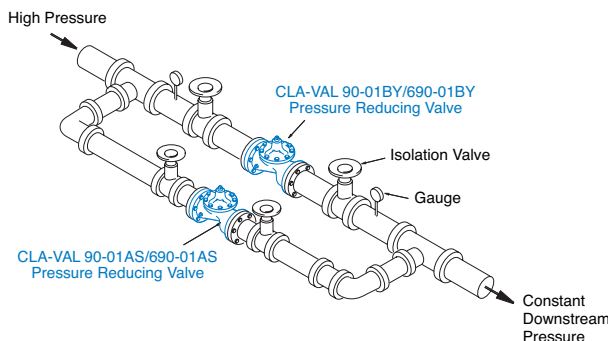

Cla-Val Model 90-01KO/690-01KO Pressure Reducing Valve with Anti-Cavitation Trim provides for optimum downstream pressure control while reducing noise and eliminating damage associated with cavitation.

See Cavitation Guide to determine if the valve is a candidate for the KO Anti-Cavitation Trim.

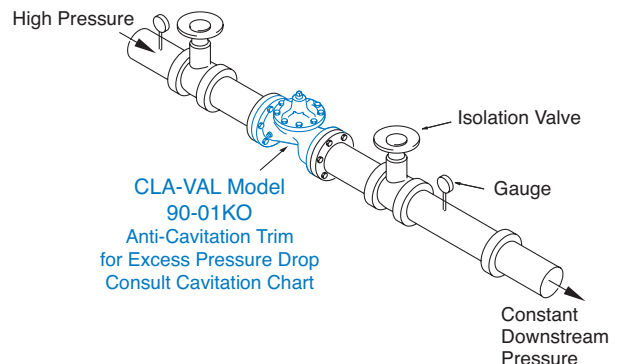

Model 90-01 (Uses Basic Valve Model 100-01)

Pressure Ratings (Recommended Maximum Pressure - psi)

Valve Body & Cover		Pressure Class			
		Flanged		Threaded	
Grade	Material	ANSI Standards*	150 lb.	300 lb.	End** Details
ASTM A536	Ductile Iron	B16.42	250	400	400
ASTM A216-WCB	Cast Steel	B16.5	285	400	400
ASTM B62	Bronze	B16.24	225	400	400

Note: * ANSI standards are for flange dimensions only.
 Flanged valves are available faced but not drilled.
 ** End Details machined to ANSI B2.1 specifications.

Materials

Component	Standard Material Combinations		
Body & Cover	Ductile Iron	Cast Steel	Bronze
Available Sizes	1½" - 36"	1½" - 16"	1½" - 16"
Disc Retainer & Diaphragm Washer	Cast Iron	Cast Steel	Bronze
Trim: Disc Guide, Seat & Cover Bearing	Bronze is Standard Stainless Steel is Optional		
Disc	Buna-N® Rubber		
Diaphragm	Nylon Reinforced Buna-N® Rubber		
Stem, Nut & Spring	Stainless Steel		

For material options not listed, consult factory.
 Cla-Val manufactures valves in more than 50 different alloys.

Dimensions (In inches)

100-01 (Globe)

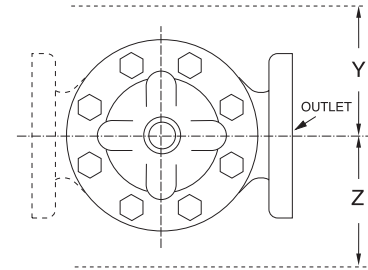
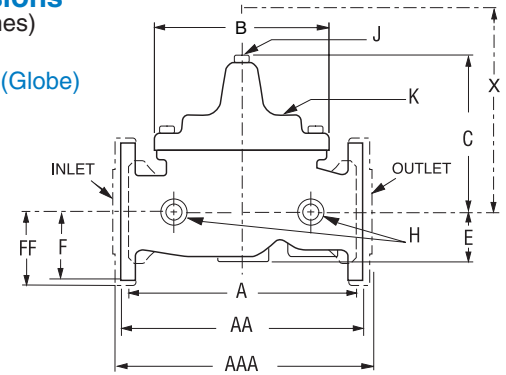

100-01 (Angle)

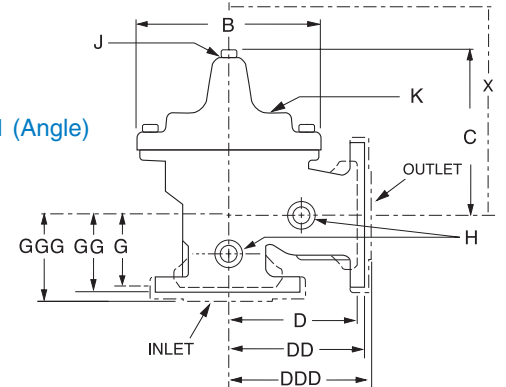

***Consult Factory

Model 90-01 Dimensions (In Inches)

Valve Size (Inches)	1½-1½	2	2 ½	3	4	6	8	10	12	14	16	20	24	30***	36***
A Threaded	7.25	9.38	11.00	12.50	—	—	—	—	—	—	—	—	—	—	—
AA 150 ANSI	8.50*	9.38	11.00	12.00	15.00	20.00	25.38	29.75	34.00	39.00	41.38	52.00	61.50	63.00	76.00
AAA 300 ANSI	9.00*	10.00	11.62	13.25	15.62	21.00	26.38	31.12	35.50	40.50	43.50	53.62	63.24	64.50	78.00
B Dia.	5.62	6.62	8.00	9.12	11.50	15.75	20.00	23.62	28.00	32.75	35.50	45.00	53.16	56.00	66.00
C Max.	5.50	6.50	7.56	8.19	10.62	13.38	16.00	17.12	20.88	24.19	25.00	41.90	43.93	54.60	61.50
D Threaded	3.25	4.75	5.50	6.25	—	—	—	—	—	—	—	—	—	—	—
DD 150 ANSI	4.00*	4.75	5.50	6.00	7.50	10.00	12.75	14.88	17.00	19.50	20.81	—	—	—	—
DDD 300 ANSI	4.25*	5.00	5.88	6.38	7.88	10.50	13.25	15.56	17.75	20.25	21.62	—	—	—	—
E	1.12	1.50	1.69	2.06	3.19	4.31	5.31	9.25	10.75	12.62	15.50	15.00	17.75	21.31	24.56
F 150 ANSI	2.50	3.00	3.50	3.75	4.50	5.50	6.75	8.00	9.50	10.50	11.75	16.50	19.25	22.50	25.60
FF 300 ANSI	3.06	3.25	3.75	4.13	5.00	6.25	7.50	8.75	10.25	11.50	12.75	16.50	19.25	24.00	25.60
G Threaded	1.88	3.25	4.00	4.50	—	—	—	—	—	—	—	—	—	—	—
GG 150 ANSI	4.00*	3.25	4.00	4.00	5.00	6.00	8.00	8.62	13.75	14.88	15.69	—	—	—	—
GGG 300 ANSI	4.25*	3.50	4.31	4.38	5.31	6.50	8.50	9.31	14.50	15.62	16.50	—	—	—	—
H NPT Body Tapping	¾	¾	½	½	¾	¾	1	1	1	1	1	1	1	2	2
J NPT Cover Center Plug	¼	½	½	½	¾	¾	1	1	1¼	1½	2	1½	1½	2	2
K NPT Cover Tapping	¾	¾	½	½	¾	¾	1	1	1	1	1	1	1	2	2
Valve Stem Internal Thread UNF	10-32	10-32	10-32	¼-28	¼-28	¾-24	¾-24	¾-24	¾-24	¾-24	¾-24	½-20	¾-16	¾-16	¾-16
Stem Travel	0.4	0.6	0.7	0.8	1.1	1.7	2.3	2.8	3.4	4.0	4.5	5.63	6.75	7.5	8.5
Approx. Ship Wt. Lbs.	15	35	50	70	140	285	500	780	1165	1600	2265	3900	6200	7703	11720
X Pilot System	11.00	13.00	14.00	15.00	17.00	29.00	31.00	33.00	36.00	40.00	40.00	47.00	68.00	79.00	85.00
Y Pilot System	9.00	9.00	10.00	11.00	12.00	20.00	22.00	24.00	26.00	29.00	30.00	34.00	39.00	40.00	45.00
Z Pilot System	9.00	9.00	10.00	11.00	12.00	20.00	22.00	24.00	26.00	29.00	30.00	34.00	39.00	42.00	47.00

*1½" Size Only

Note: The top two flange holes on valve size 36 are threaded to 1 1/2"-6 UNC.

Model 690-01 (Uses Basic Valve Model 100-20)

Dimensions
(In inches)

Pressure Ratings (Recommended Maximum Pressure - psi)

Valve Body & Cover		Pressure Class		
		Flanged		
Grade	Material	ANSI Standards*	150 lb.	300 lb.
ASTM A536	Ductile Iron	B16.42	250	400
ASTM A216-WCB	Cast Steel	B16.5	285	400
ASTM B62	Bronze	B16.24	225	400

Note: *ANSI standards are for flange dimensions only.
Flanged valves are available faced but not drilled.

100-20 (Globe)

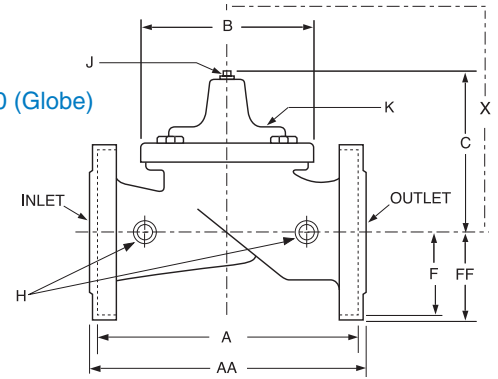

Materials

Component	Standard Material Combinations		
Body & Cover	Ductile Iron	Cast Steel	Bronze
Available Sizes	3" - 48"	3" - 16"	3" - 16"
Disc Retainer & Diaphragm Washer	Cast Iron	Cast Steel	Bronze
Trim: Disc Guide, Seat & Cover Bearing	Bronze is Standard Stainless Steel is Optional		
Disc	Buna-N® Rubber		
Diaphragm	Nylon Reinforced Buna-N® Rubber		
Stem, Nut & Spring	Stainless Steel		

For material options not listed, consult factory.
Cla-Val manufactures valves in more than 50 different alloys.

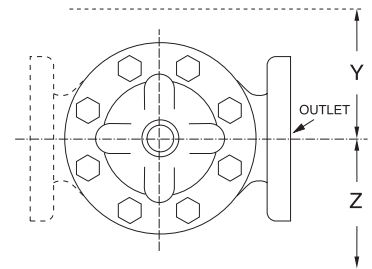

100-20 (Angle)

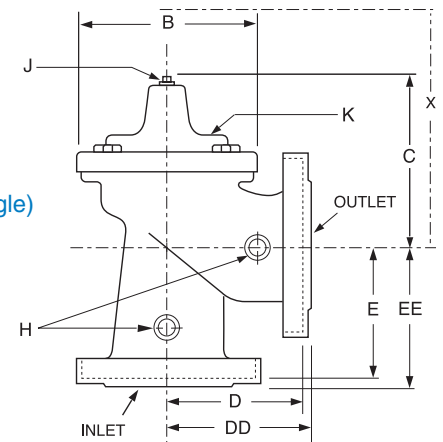



***Consult Factory

Model 690-01 Dimensions (In Inches)

Valve Size (Inches)	3	4	6	8	10	12	14	16	18	20	24	30	36***	42***	48***
A 150 ANSI	10.25	13.88	17.75	21.38	26.00	30.00	34.25	35.00	42.12	48.00	48.00	63.25	65.00	76.00	94.50
AA 300 ANSI	11.00	14.50	18.62	22.38	27.38	31.50	—	36.62	43.63	49.62	49.75	63.75	67.00	76.00	94.50
B Dia.	6.62	9.12	11.50	15.75	20.00	23.62	24.47	28.00	35.44	35.44	35.44	53.19	56.00	66.00	66.00
C Max.	7.00	8.62	11.62	15.00	17.88	21.00	20.88	25.75	25.00	31.50	31.50	43.94	54.60	61.50	61.50
D 150 ANSI	—	6.94	8.88	10.69	—	—	—	—	—	—	—	—	—	—	—
DD 300 ANSI	—	7.25	9.38	11.19	—	—	—	—	—	—	—	—	—	—	—
E 150 ANSI	—	5.50	6.75	7.25	—	—	—	—	—	—	—	—	—	—	—
EE 300 ANSI	—	5.81	7.25	7.75	—	—	—	—	—	—	—	—	—	—	—
F 150 ANSI	3.75	4.50	5.50	6.75	8.00	9.50	11.00	11.75	15.88	14.56	17.00	19.88	25.50	28.00	31.50
FF 300 ANSI	4.12	5.00	6.25	7.50	8.75	10.25	—	12.75	15.88	16.06	19.00	22.00	27.50	28.00	31.50
H NPT Body Tapping	3/8	1/2	3/4	3/4	1	1	1	1	1	1	1	1	2	2	2
J NPT Cover Center Plug	1/2	1/2	3/4	3/4	1	1	1 1/4	1 1/4	2	2	2	2	2	2	2
K NPT Cover Tapping	3/8	1/2	3/4	3/4	1	1	1	1	1	1	1	1	2	2	2
Valve Stem Internal Thread UNF	10-32	1/4-28	1/4-28	3/8-24	3/8-24	3/8-24	3/8-24	3/8-24	1/2-20	1/2-20	1/2-20	1/2-20	3/4-16	3/4-16	M20
Stem Travel	0.6	0.8	1.1	1.7	2.3	2.8	3.4	3.4	3.4	4.5	4.5	6.5	7.5	8.5	8.5
Approx. Ship Wt. Lbs.	45	85	195	330	625	900	1250	1380	1500	2551	2733	6500	8545	12450	13100
X Pilot System	13.00	15.00	27.00	30.00	33.00	36.00	36.00	41.00	40.00	46.00	55.00	68.00	79.00	85.00	86.00
Y Pilot System	10.00	11.00	18.00	20.00	22.00	24.00	26.00	26.00	30.00	30.00	30.00	39.00	40.00	45.00	47.00
Z Pilot System	10.00	11.00	18.00	20.00	22.00	24.00	26.00	26.00	30.00	30.00	30.00	39.00	42.00	47.00	49.00

Note: The top two flange holes on valve sizes 36 thru 48 are threaded to 1 1/2"-6 UNC.

Valve Selection		These Symbols  and  Indicate Available Sizes																																																																																																																																																																																																																																																																																																																																																														
		Inches	1¼	1½	2	2½	3	4	6	8	10	12	14	16	18	20	24	30	36	42	48																																																																																																																																																																																																																																																																																																																																											
		mm	32	40	50	65	80	100	150	200	250	300	350	400	450	500	600	750	900	1000	1200																																																																																																																																																																																																																																																																																																																																											
End Detail		Threaded	Threaded & Flanged										Flanged																																																																																																																																																																																																																																																																																																																																																			
Model 90-01	Basic Valve 100-01	Globe	